A Cost-Oriented Approach for Infrastructural Design

Danilo Ardagna



Politecnico di Milano
Italy

Summary

- Research objectives and Motivation
- Presentation of proposed methodology
- Empirical verifications
- Conclusions and Future Work

Research objectives and Motivation

- Objectives

- ▶ Support the Architectural Design of IT Systems minimizing TCO

- Motivation

- ▶ The Architectural design of IT systems is traditionally led optimizing single subsystems separately
- ▶ Fill literature gap

The Infrastructural design proces

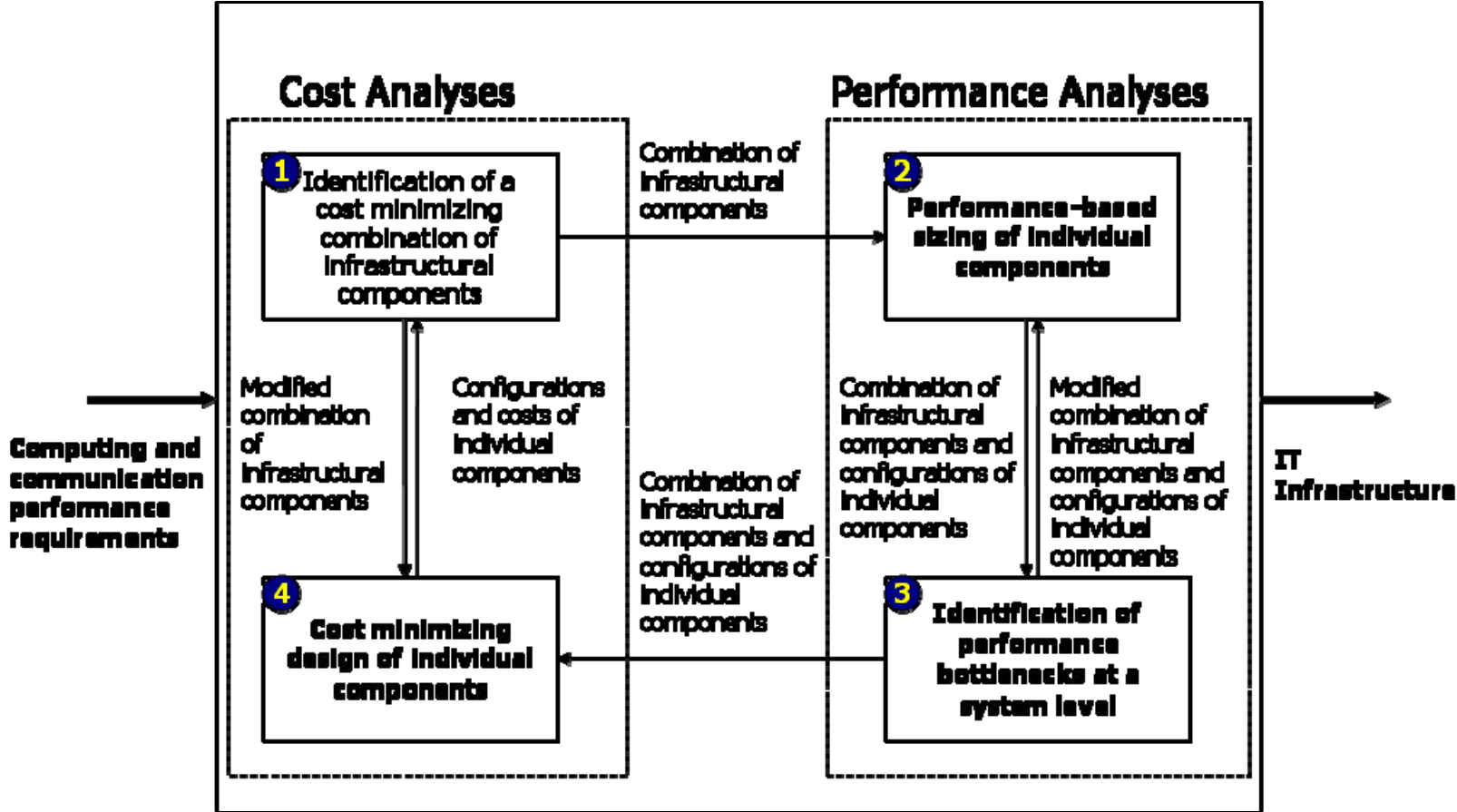

Design Methodology: architectural alternatives

- Client typology, thin vs. fat vs. hybrid fat client (HFC)
- Number of tiers
- Total number of servers
- Allocation of applications
- Reuse of legacy systems
- Location of servers
- Network topology and standards

Technology Requirements

- Organization Sites S_i
- User classes C_i
- Applications A_i
- Requests R_i
- Databases D_i

Cost minimization algorithm

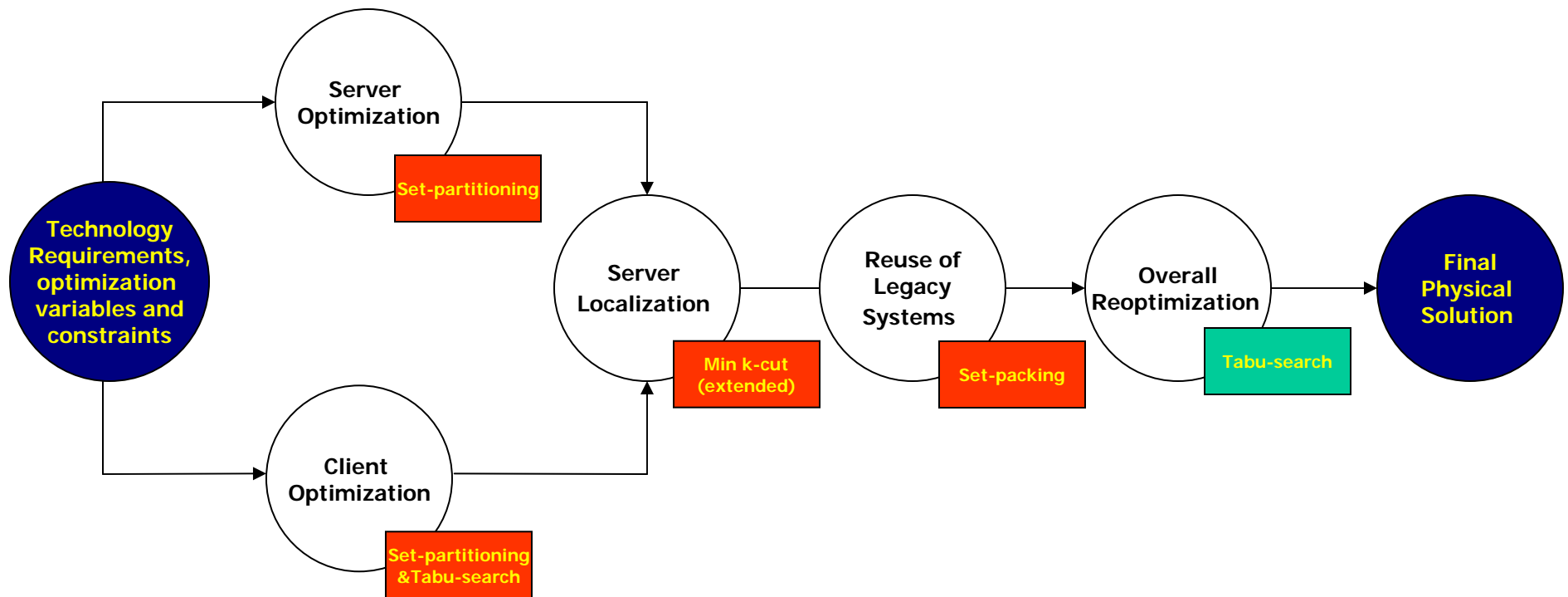

ISIDE

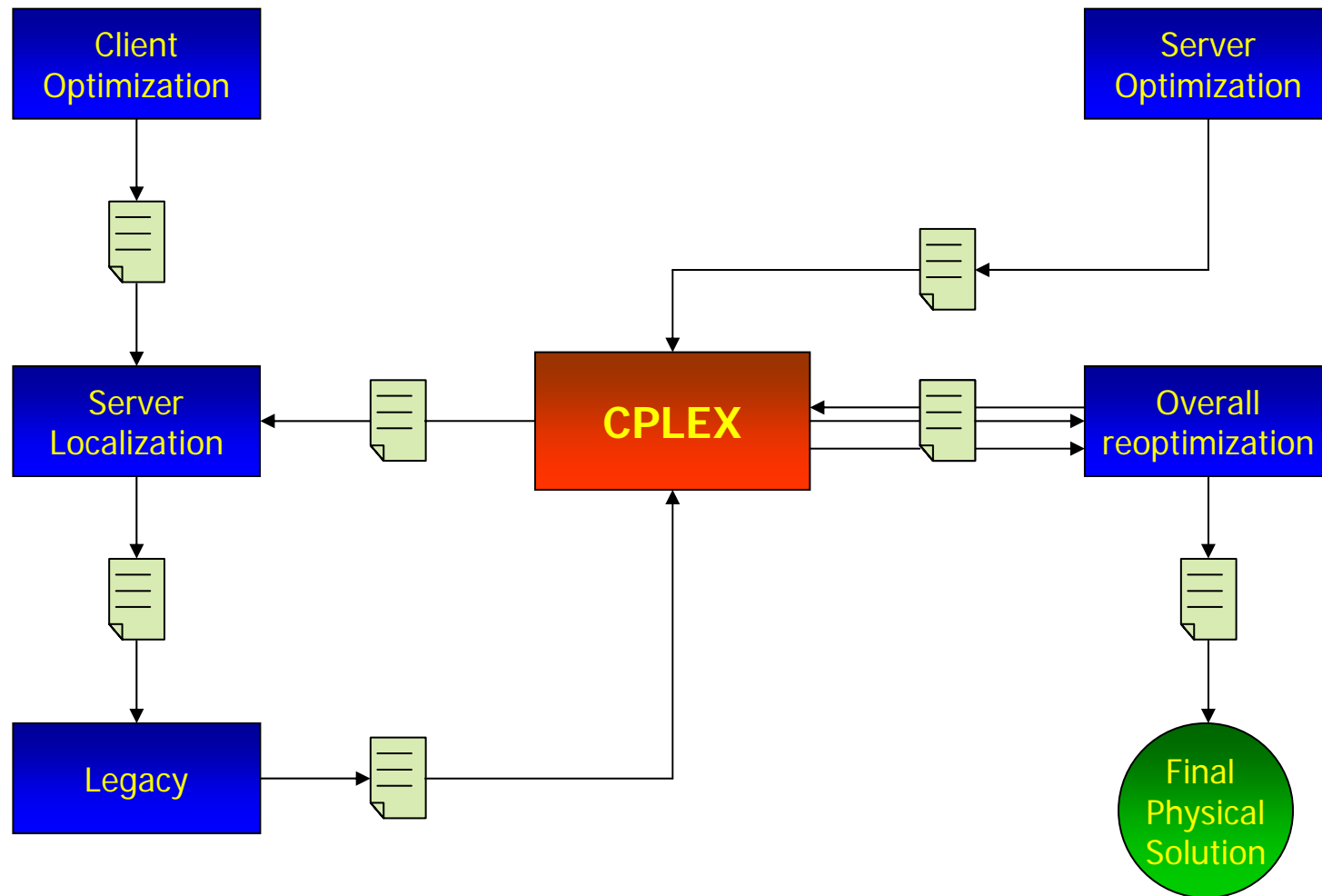

Empirical verifications

- The cost and time efficiency are evaluated by considering the output of the last tabu-search optimization step operating on an initial solution obtained as follows:
 - ▶ Thin clients and HFCs are adopted whenever possible
 - ▶ Server farms are implemented whenever possible and designed by selecting the smallest server that can support applications
 - ▶ Applications are allocated with the maximum number of tiers allowed by constraints
 - ▶ Applications that can be grouped are centralized on a single server/server farm
 - ▶ Application servers that are not constrained to a specific location are centralized in the site that minimizes VPN bandwidth requirements

Case Studies

- A multi-department University:
 - ▶ 7 departments with 3 user classes, 100 users each (administrative staff, software and electronic engineering researchers)
 - ▶ Browser, e-mail client, office automation suite, IDE, circuit simulator
 - ▶ Local e-mail server, a web/proxy server applications
- An Internet banking system
 - ▶ 3 data centers, 250,000 Internet users
 - ▶ A web server, a servlet engine, an application server, a relational DBMS, an object-oriented database

TCO as a function of optimization time

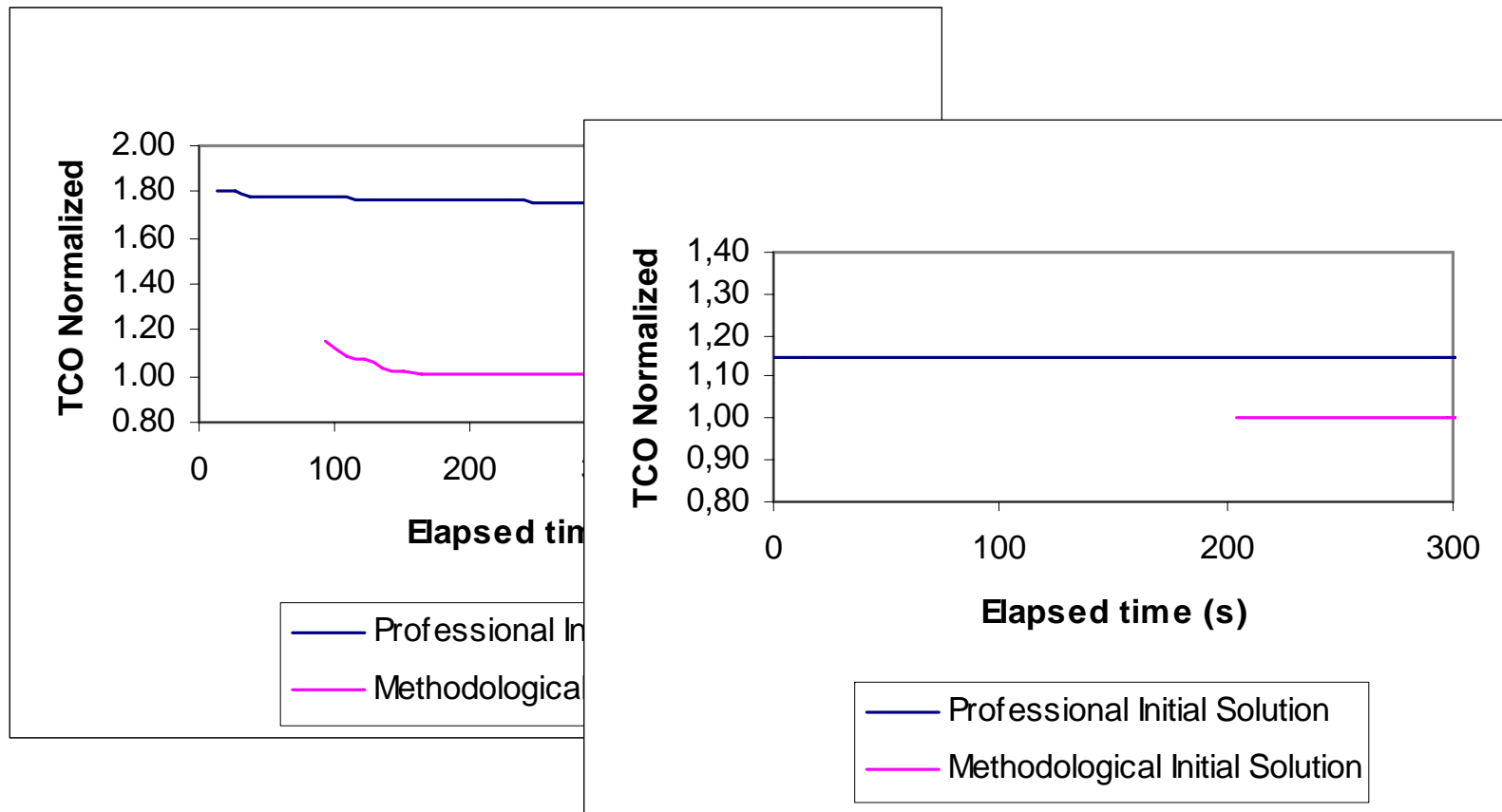

Conclusions and Future Work

- Results indicate that the decomposition of the overall NP-hard problem into four sub-problems significantly reduces optimization time
- Solutions are also closer to the global optimum, as they have lower costs than those identified with a local-search approach without prior decomposition (20-60%)
- Cost reductions considerably grow (25-70%) when methodological outputs are compared with practitioners' solutions obtained by applying simplified design rules from the professional literature

Conclusions and Future Work

- Future work will consider the integration of the cost-oriented methodology with traditional performance analyses, which provide more precise sizing information of infrastructural components
- The range of design alternatives will also be completed, by extending the methodology to include network design alternatives